



Easikey 250
User and Installation Guide

17410 v1.1 Nov 2011

STANLEY
Security Products



Table of Contents

Easikey 250.....	3
Description.....	6
How to Use the Easikey 250.....	7
Installation.....	13
Boxed Easikey 250.....	23
Initial Programming.....	29
Set-Reset Latch.....	37
Database Copy.....	38
Dual Controller Option.....	41
Easikey 250 System Troubleshooting.....	44
Other Easikey 250 Products.....	45
Standards.....	46
Specification.....	47

Easikey 250

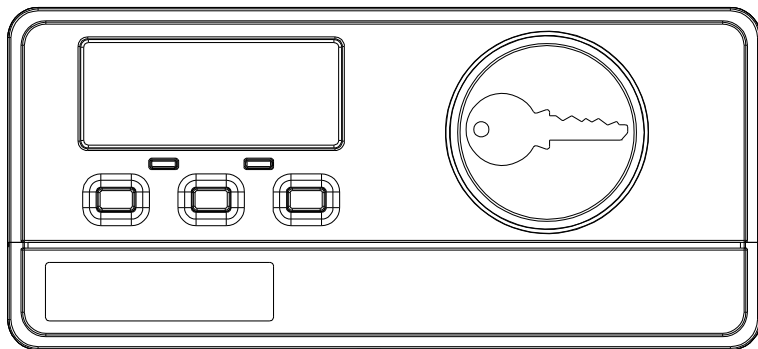

Facilities

- Simple proximity access control
- Compatible with several types of reader
- Controls one or two doors
- Up to 250 keyholders
- Up to three Editor Keys
- Individual keys may be added and deleted
- Each lock may be Fail-Safe (Fail Open) or Fail-Secure (Fail Closed)
- Request to Exit input
- Set-Reset option, (e.g. for alarm setting)
- Dual Controller option – 2 doors, 500 keyholders

Features

Maximum Number of Keys:	250 (500 if using dual controllers)
Number of Doors:	2
Types of Reader:	OneProx Classic Standard OneProx Designer Standard OneProx Classic Mullion OneProx Designer Mullion OneProx Vandal Resistant OneProx Panel Mount Easikey Mullion (compatible legacy reader) Easikey Vandal Resistant (compatible legacy reader) Easikey Panel Mount (compatible legacy reader)
Access Levels:	3 (allowed through Door 1, Door 2 or both doors)
Lock Release Time:	1–49 seconds
Lock Type:	Fail-Safe or Fail-Secure
Number of Editor Keys:	Selectable (1, 2 or 3)
Other Features:	Request to Exit input Set-Reset Latch Database copy Display last 5 keys given access

About this Guide

This document contains details on installing and using the Easikey 250 system. **Installers** should read this entire Guide before continuing with the installation of the system. If you are already familiar with this product then there is a Quick Start section which will remind you of the stages of installing and programming the system.

Users and **Administrators** should read the section How to Use the Easikey 250. This section also describes how to use the Worksheets provided. Users should also read the sections on Adding a Key, Deleting Keys and Showing the Last 5 Users.

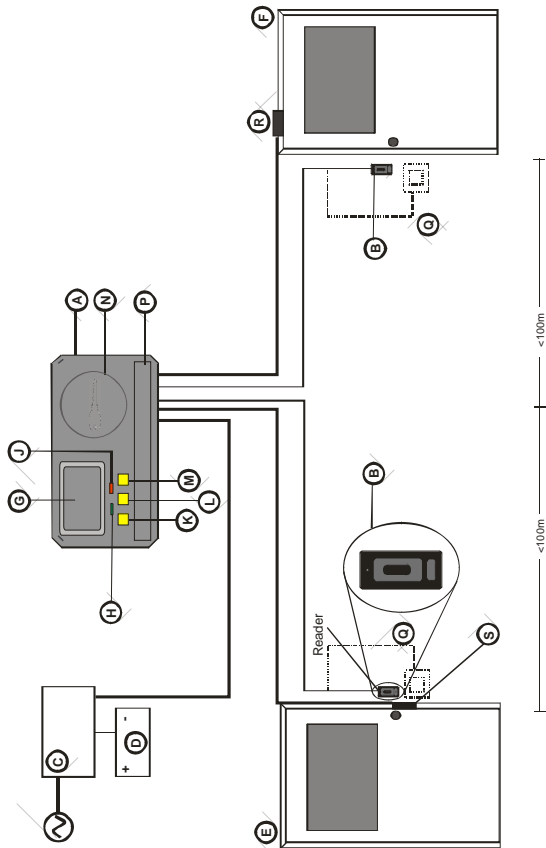

Easikey System Configuration

<p>A Easikey 250</p> <p>B Reader Supply for Controller, Readers and Locks</p> <p>C Battery Backup</p>	<p>E Door 1</p> <p>F Reader</p> <p>G LCD Display</p> <p>H Green LED</p> <p>J Red LED</p>	<p>K Left Button</p> <p>L Right Button</p> <p>M Controller Reader</p> <p>N Removable Cover</p>	<p>Q Request to Exit Switch (in either direction)</p> <p>R Electric Lock</p> <p>S Magnetic Lock</p> <p>Example: Electric Release</p>
--	---	--	---

<p>Readers may be:</p> <p>OneProx Reader (shown)</p> <p>Easikey Reader</p>	<p>Locks may be:</p> <p>Fail Secure, e.g. Electric Release</p> <p>Fail Safe, e.g. Magnetic Lock</p>
---	--

Description

The Easikey 250 (P/N 20370) is a simple two door access control system using Stanley Security Products' proximity readers and electronic keys. The system allows you to control the access of up to 250 keys through one or two doors.

Components

An Easikey 250 system consists of an Easikey 250 door controller, one or two readers and up to 250 keys. In addition you will require a power supply, cable and suitable electric locks. Optional items include Request to Exit switches and backup batteries. Stanley Security Products also provide a **Boxed Easikey**, consisting of an Easikey 250 controller housed in a steel cabinet, complete with 3A power supply, space for backup batteries and complete internal wiring.

How it Works

Each PAC key contains a unique code. The controller can store the code of up to 250 keys in its non-volatile memory. When a key is presented to a reader, the code in the key is passed by the reader to the controller. It is then compared to the codes in the controller's memory. If the key is recognised by the controller then a relay will be operated allowing the release of an electric lock.

Programming

An Easikey 250 system is programmed through the use of **Editor Keys**. The first one, two or three keys in the controller's memory are defined as Editor Keys — you select how many at installation.

By use of the Editor Keys, an operator may add and delete user keys from the controller's memory using the built-in reader.

An LCD display is used to indicate user key and system information.

The display also includes two LEDs (light emitting diodes), red and green, for providing extra indications depending on the type of operation being performed.

How to Use the Easikey 250

This section describes how you should use your Easikey 250 system to its best advantage. Anyone operating or administering the system should read this section as well as becoming familiar with Adding Keys and Deleting Keys.

Worksheets

Each Easikey 250 controller is supplied with a set of Programming Worksheets. We strongly recommend that you use these for recording information about the system as well as for keeping a record of keyholders. This enables you to find a key on the system, e.g. if you want to replace a key. The following paragraphs refer to the Programming Worksheets and how best to use them.

Editor Keys

An Easikey 250 controller can store up to 250 keys in its memory. Door access permission can be set for every key as follows: Door 1 only, Door 2 only or both doors.

Up to three of these user keys are also given the ability to make changes to the system — such as adding new keys or deleting existing keys. These are known as **Editor Keys**. When the system is first installed the number of Editor Keys is set.

You should know how many user keys are also Editor Keys; if you do not, then find out from whoever installed the system. There is a section on the *Programming Worksheet* to record this number.

It is recommended that you assign two or three keys as editors, and keep at least one in a safe place. Editor Keys can be deleted and added just like normal keys. However if all your Editor Keys are lost, you must follow the procedure to replace Editor Key 0. You cannot change the total number of Editor Keys without clearing the whole memory.

Administering Keys

Each key added to the system is given a number, 0–249. The lowest available number is displayed when a new key is presented, although this can be changed to another unused number if necessary. When a key is deleted from the Easikey 250's memory, its number becomes available again.

If you wish to change an existing key's number or its door permissions, you must first delete it from the system and then add it as a new key with the correct information.

When you add a new key to the Easikey 250 system you need to record the number (0-249) it was given, and to whom it was issued. This is important so that if the keyholder loses the key you can delete it by entering its 3-digit number. Use the Worksheets supplied for this purpose.

You can identify keys that have been found by presenting them to the controller reader. Their 3-digit number will be displayed, along with a red LED. (If a green LED is displayed, it means the key is unknown to the Easikey 250.)

The worksheet has an unlabelled column in the keyholder section. You can use this for recording your own information. Typically you may record Department or Office in a commercial system, or Flat, Building or Block in a residential system.

For residential users different coloured clips are available. These clip over the top of the PAC key. You can use these clips to identify different keys issued to one keyholder. A residential system, for instance, may issue a red, blue and yellow key to one resident for use by the occupants of one dwelling. If one key is lost they can refer to their "red key" as being missing.

The worksheets contain a column for indicating the colour given to a key.

A grid on one side of the PAC key can also be used for physically marking a key. You put a small scratch, or drop of paint or correcting fluid, in different boxes to identify individual keys.

Residential Systems

Two special worksheets are included that are designed for use in Residential applications. They are labelled **Staff** and **Residents**. You should use the **Staff** worksheet for recording personnel such as cleaners, maintenance staff, housing officers, etc., and the **Residents** worksheet for the residents.

Adding a Key

1. Present the key:

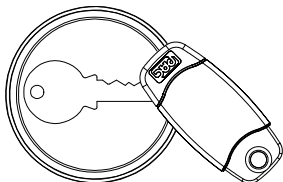

New user : 3
1:Y 2:Y

2. Change key number?

Press the middle button:



Press to change hundreds: Press to change tens: Press to change units:



Present the key again:

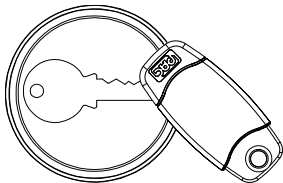

Free index : 3

Free index : 38

New user : 38
1:Y 2:Y

3. Change access level?

Press to change Door 1 access: Press to change Door 2 access:

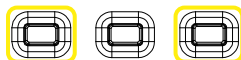

New user : 38
1:Y 2:N

Note: You cannot change the access level to 1:N 2:N.

4. Present an Editor Key:

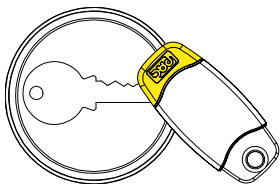

User key : 38
Saved



User key : ...
1:Y 2:N

5. Add more keys?

Yes: Continue to **Batch Mode** within 15 seconds.

No: Present an Editor Key again, or wait 15 seconds.

Batch Mode

1. Change access level for keys you are about to add?

Press to change

Press to change

Door 1 access:

Door 2 access:



User key : ...
1:N 2:Y

Note: You cannot change the access level to 1:N 2:N.

2. Present each key in turn:

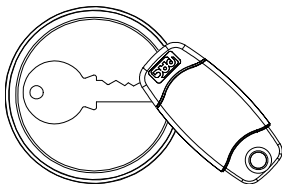

User key : 39
Saved



User key : ...
1:N 2:Y

3. Add more keys?

Yes: Repeat Step 1 and Step 2 as required.

No: Present an Editor Key, or wait 15 seconds.

Possible Issues

Key already in controller's memory –
present a different key instead:

User key : 23
Saved

Key already in controller's memory (batch mode) –
present a different key instead:

Key exists : 23
Saved

Memory full – you must delete some keys before you
can add any more:

Memory is Full

Editing Keys

To change a key's number or access level, first delete the key, then add it again selecting a different key number and / or access level.

Deleting Keys – Method 1

1. Present the key to be deleted:

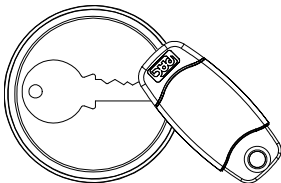

User key : 38
Saved

2. Present an Editor Key:

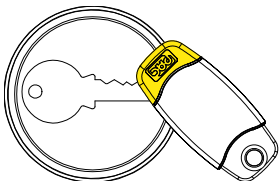

Erased : 38

Note: You cannot delete an Editor Key this way.

Deleting Keys – Method 2

1. Press the Right button:

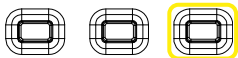

Erase token : 0

2. Enter the number of the key:

Press to Press to Press to
change change change
hundreds: tens: units:



Erase token : 38

3. Present an Editor Key:

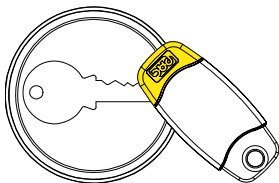

Erased : 38

Note: You cannot use an Editor Key to delete itself.

Showing the Last 5 Users

1. Press the Left button:

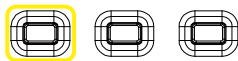

Last 5:1B 1A 0B
0B 7B

0-249 – Key number, **A** – Door 1, **B** – Door 2.

2. Press the Left button again to clear screen:

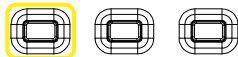

Installation

The installation must meet the requirements of the country of installation's National Wiring Regulations and EN60950-1. It must be only carried out by competent, qualified and experienced personnel. Failure to do so can result in injury or death by electric shock.

Note: See the section on Boxed Easikey 250 for further instructions relating to the installation of a Boxed Easikey 250 or Boxed Easikey 250 with Cutout.

Quick Start

If you have installed an Easikey 250 system before then you can follow this simple step-by-step checklist to get the system up and running. If you are new to Easikey 250 then all the steps below are described in detail in the following pages.

Step		✓
1.	Install the Easikey 250 controller and power supply in an enclosure or other secure area.	
2.	Install the readers and reader cables, including any request to exit switches.	
3.	Install the electric locks and their cables.	
4.	Initialise the Easikey 250, set the number of Editor Keys and add one or more keys.	
5.	Set the lock release time for each lock.	
6.	Check the operation of each reader and lock.	
7.	Add any remaining keys to the controller — use the Worksheet to record details of keyholders.	

Mounting the Easikey 250 Controller

The controller should be mounted in a lockable cabinet or enclosure containing the power supply and batteries, if used. It should be easily accessible for programming – the display should be at about eye level.

Note: The Easikey 250 has the same dimensions as the Easikey 99.

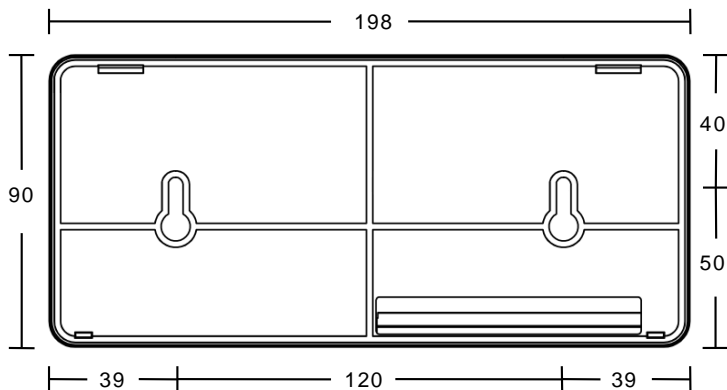

Easikey 250 Mounting Plate Dimensions (mm)

Mounting the Unit

1. If using the provided mounting plate, secure the mounting plate using two countersunk screws. Take care not to over-tighten the screws as distortion of the mounting plate may make it difficult to mount the controller:

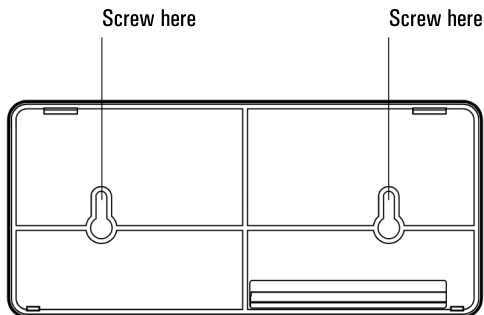

2. Locate the two slots in the top edge of the unit into the two tabs indicated below and apply gentle pressure to the bottom edge until the two latches lock into place:

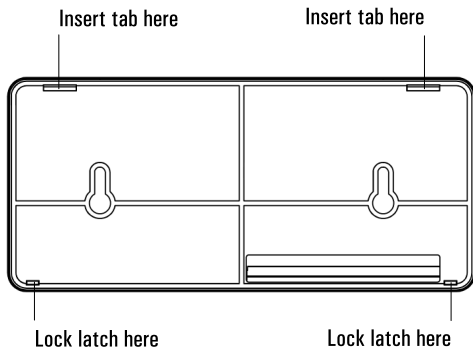

3. Locate the latches on either side of the cable cover into the slots inside each edge of the upper case:

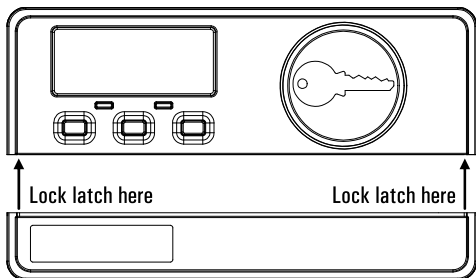

4. Secure the cable cover using the screw hole located in the underside of the cable cover:

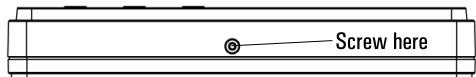

Removing the Unit

1. Take out the securing screw and apply gentle forward pressure to the underside of the cable cover which should cause it to unlatch from the upper section.
2. Locate the loop latches each side and squeeze them to release the unit from the mounting plate:

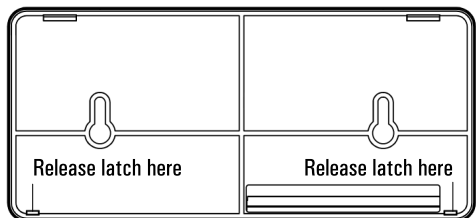

3. While supporting the unit, lower it from the mounting plate locating tabs.

Terminal Blocks

All connections are made to the controller by removable terminal blocks. Always remove power from the controller before removing a terminal block.

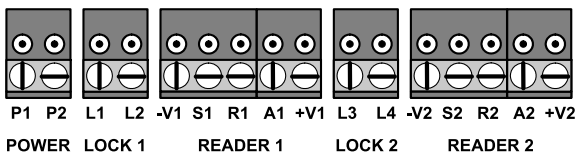

Terminal Blocks

Terminal Block:	Function:
POWER	Power Input, AC or DC
LOCK 1	Lock 1 Output
READER 1	Reader Channel 1
LOCK 2	Lock 2 Output
READER 2	Reader Channel 2

Power Supply

The Easikey 250 controller and readers are powered from a 12v AC or DC power supply. The locks are controlled by switching power from the same or different supply. The relays that control the locks are able to switch 24v DC at up to 2 Amps. A power supply with battery backup should be selected to provide operation when mains power is lost.

The power supply chosen should be capable of supplying sufficient current to power the Easikey 250 controller, one or two readers, and one or two electric locks, and provide charging current for the battery.

Connecting Power

Power is supplied through the P1 and P2 terminal block. See the section Installing Locks and Power Supply for details of power and lock wiring.

Battery Backup

The length of time that a backup battery will last depends on the power consumption of the system.

The main factor here is the power consumption of the locks. A **Fail-Safe** (Fail Open) lock requires current continuously while a **Fail-Secure** (Fail Closed) lock only draws current when it operates. You need to estimate how often the lock will operate and then use the following equation to estimate consumption:

Consumption = Lock Current × (Operations per hour × lock release time) / 3600

Example

A 500mA lock operating 100 times an hour for 5 seconds would use $500 \times (100 \times 5) / 3600 = 69\text{mA}$ per hour.

Once the total power consumption has been estimated then it can be calculated how long the fully charged batteries will last. The Ah rating of batteries is usually given as a 10 hour discharge rate. If the batteries discharge over a shorter period of time they will last for less than their quoted capacity.

Example

An Easikey 250 with two readers and two continuous (Fail-Safe) locks each drawing 250mA would consume $190 + 90 + 90 + 250 + 250 = 870\text{mA}$. A fully charged 12Ah battery would last $12 / 0.870 = 13.7$ hours.

Readers

Install readers according to the instructions supplied with each reader. Readers are usually installed at about door handle height on the unhinged side of the door.

All readers have the same wiring terminals, and are fitted with a green LED that illuminates when access is allowed, and stays illuminated for the duration of the lock release time.

The maximum distance of a reader from the controller is **100m**.

If two readers are fitted then they must be at least **300mm** apart.

The Easikey 250 is compatible with OneProx readers and Easikey readers.

Request to Exit (RTE)

A Request to Exit switch may be fitted on the secure side of the door. This should be a normally-open switch that closes momentarily when pressed and released. Do not allow the wiring for the RTE switch to be visible if the reader is removed from the wall.

Reader Wiring

If you do not intend to use the RTE switch then unscreened 4-core cable will be suitable; otherwise use 6-core cable.

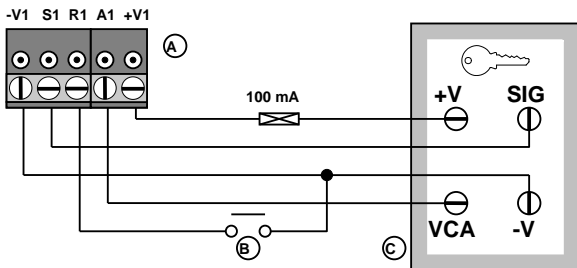

Reader Wiring, including RTE

A	Terminal Block	B	RTE	C	Reader
---	----------------	---	-----	---	--------

Use 7/0.2mm (0.22mm²) 4-core or 6-core unscreened cable.

Controller:		Colour:	Reader:
Channel 1	Channel 2		
+V1	+V2	Red	+V
S1	S2	White	SIG
R1	R2	N/A	(RTE)
A1	A2	Yellow	VCA
-V1	-V2	Black	-V

Note: The reader outputs are set at 90mA. Stanley Security Products strongly recommend that you fit a 100mA in-line fuse in the reader supply.

Installing Locks and Power Supply

Locks should be installed according to the manufacturer's instructions. The Easikey 250 controls the operation of a lock by switching power using a voltage-free relay. Up to 24v DC at 2 Amps may be switched by the relays. Each lock may be programmed to be Fail-Safe (continuously powered, power removed to unlock) or Fail-Secure (power supplied to unlock). The type of cable used should be sufficient to provide the correct operating voltage at the lock. Usually at least 0.5mm² will be required for a range of up to **100m**.

Lock Suppression

Important

All PAC readers are supplied with a suppression device, a MOV (metal oxide varistor). This device should be fitted across the lock supply at the lock. These devices prevent harmful back E.M.F. ("spikes") from damaging the Easikey 250 controller. Failure to fit these devices may result in long term damage to the controller and possible problems of door sticking.

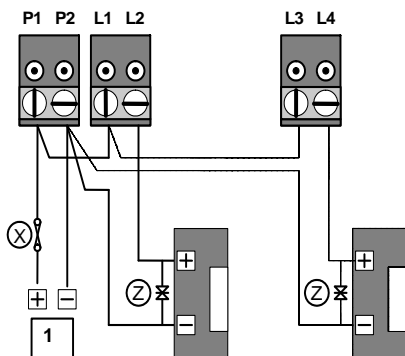

Single Power Supply

X	Fuse	Z	MOV
---	------	---	-----

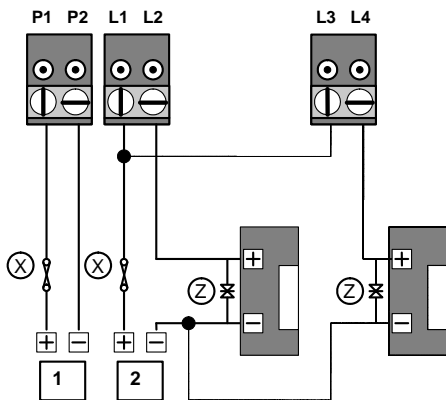

Separate Power Supply for Controller and Lock

X	Fuse	Z	MOV
---	------	---	-----

Health and Safety

Any installation must comply with any local Fire, Health and Safety regulations. A secured door that may be part of an escape route from an area should be fitted with:

- A **Fail-Safe lock (A)**, so that the door will be released if the power fails. Ideally a magnetic lock should be used as these are less likely to jam or seize.
- A normally-closed **Break-Glass or Manual Pull (B)** in the lock supply wiring, so that in an emergency the Fail-Safe lock can be immediately depowered.

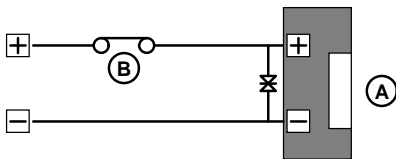

Checking the System

After completing the wiring of power supply, readers and locks you should make the following checks.

Checking the System

1. Remove power. Remove all terminal blocks except for the power supply (P1 and P2). Apply power.
You should have between 10.5 and 20V DC or between 8 and 14.5V AC across P1 and P2.
2. Remove power. Connect Reader 1 terminal block. Apply power.
You should have between 10 and 16V DC at the controller (+V1, -V1) and 9–16V DC at the reader (+V, -V).
3. Repeat for Reader 2, if used.

Boxed Easikey 250

The Boxed Easikey 250 (P/N 21275) and Boxed Easikey 250 with Cutout (P/N 21277) consist of an Easikey 250 controller housed in a metal cabinet, complete with 3 Amp power supply and wiring. With the addition of readers, electronic keys and electric door locks, a complete two door access control system can be installed. The assembly as supplied provides the following features:

- 18 swg Mild Steel Cabinet with hinged lid with space for two 6Ah Batteries
- 3 Amp Power Supply with Battery Backup provision — batteries not supplied
- Easikey 250 two door Controller
- All internal wiring provided, including fuses
- Alternative entry points for external wiring at rear and side (conduit or trunking)
- Cover secured with lock and key

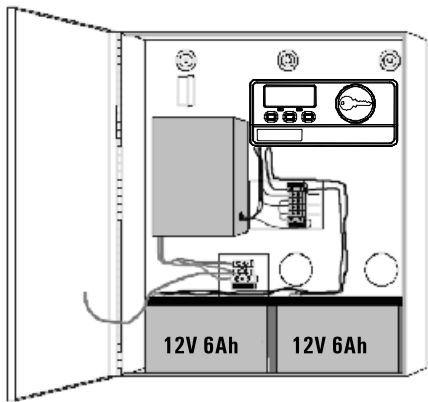

Boxed Easikey 250

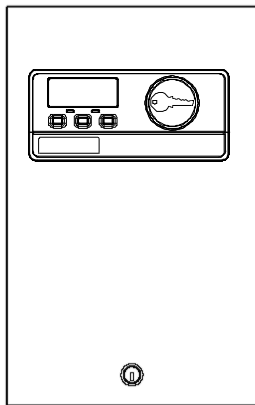

Boxed Easikey 250 with Cutout

Installing the Boxed Easikey 250

See Installation for full details on installing the Easikey 250 system. Instructions specific to the Boxed Easikey 250 / Boxed Easikey 250 with Cutout are given here.

Mounting the Cabinet

The cabinet should be mounted vertically on a flat wall. As the controller is used for administering the system you should ensure that the cabinet is located in a well lit, comfortable location allowing personnel easy access. The cabinet should be positioned so that the controller display is at about eye-level.

Mounting the Cabinet – Boxed Easikey 250

1. Using the keyhole at the top centre as a pivot, temporarily hang the cabinet and use the four corner holes as a template to mark the position of the fixing points.
2. Use N° 8 1½" self-tapping screws and appropriate fixings to attach the cabinet to the wall.

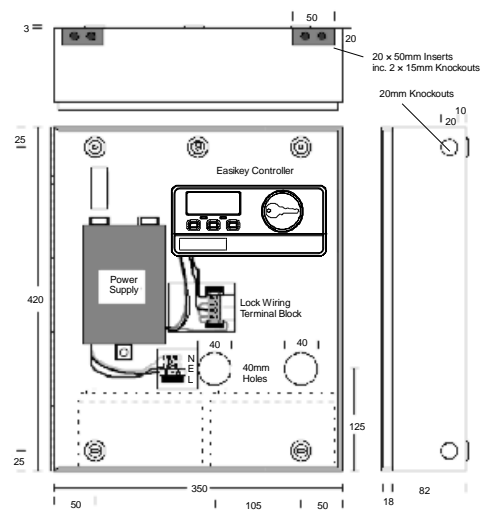

Mounting the Cabinet – Boxed Easikey 250 with Cutout

1. Using the keyholes at the top as a template, temporarily hang the cabinet and then use the two lower holes as a template to mark the position of the fixing points.
2. Use N° 8 1½" self-tapping screws and appropriate fixings to attach the cabinet to the wall.

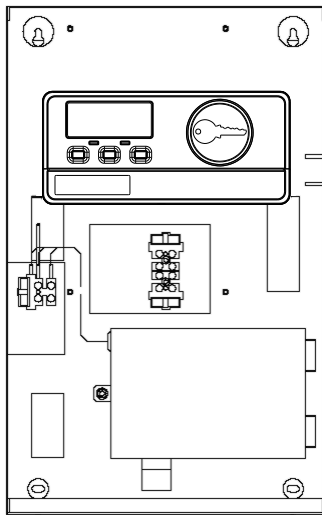

Power Supply Wiring

The cabinet already contains wiring from the power supply to the Easikey 250 controller and to the battery wiring harness (although batteries are not supplied). Wiring is also in place bringing the lock outputs to a terminal block below the Easikey 250 controller.

Cable Entry Options – Boxed Easikey 250

- Two 40mm holes in the back of the cabinet for rear entry.
- A 20mm knockout at the top and bottom of each side for surface mounted conduit.
- A 20mm × 40mm removable plastic insert at each side of the top and bottom surfaces for surface mounted trunking. Each insert also has two 15mm knockouts.

Cable Entry Options – Boxed Easikey 250 with Cutout

- Two holes in the back of the cabinet for rear entry.
- Two knockouts on the top suitable for use with 25 × 16mm trunking.
- A 20mm knockout at the bottom of each side for surface mounted conduit.
- Two 20mm knockouts on the bottom for surface mounted conduit.

Mains Power

Mains power, 240v AC, should be supplied to the controller through an illuminated, unswitched spur. Use the following colour code:

Blue:	Neutral
Green / Yellow:	Earth
Brown:	Live

Fuses

Location	Type	Rating
Mains Terminal Block	20mm glass, Slow Blow	1 Amp
Lock Supply *	20mm glass, Slow Blow	3.15 Amp
Battery Lead *	20mm glass, Slow Blow	3.15 Amp

Note: The Lock Supply and Battery fuses are located in a terminal block below the Easikey 250 controller.

Internal Power Wiring

The diagram below describes the wiring provided inside the cabinet. This provides for battery backup through a harness capable of connecting two batteries, and two lock 12v lock outputs through a terminal block.

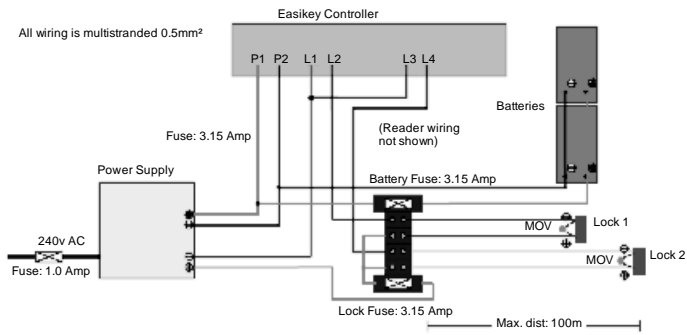

Reader Wiring

See the section on Reader Wiring for instructions on reader wiring.

Lock Wiring

See the section on Installing Locks and Power Supply for information on lock wiring.

Battery Backup

There is room in the cabinet for two 6Ah batteries giving a total of 12 Ah supply. See the section on Battery Backup for more information.

Power Supply Specification

The power supply is capable of supplying a maximum of 3 Amps. This should be sufficient to power the Easikey 250 controller, one or two readers and one or two electric locks, and provide charging current for the battery.

Use the following table to ensure you do not overload the power supply:

Item	Current (mA)
Easikey 250 Controller	190
Reader 1	90
Reader 2	90
Lock 1	
Lock 2	
Charging Current	500
Safety Margin	500
Total	

The total current should not exceed 3A (3000mA). This leaves approximately 1600mA available for supplying the locks on a two door system.

Checking the System – Boxed Easikey 250 / Boxed Easikey 250 with Cutout

1. With the mains supply connected, power up the system with no locks or readers connected.
2. Using a multimeter set to DC volts, measure the voltage across the P1 and P2 terminals of the Easikey 250 controller.

The voltage should read between 13.5 and 13.8v DC.

3. If you are using battery backup, power up with the battery (or batteries) connected and measure the voltage between P1 and P2.

This should still be between 13.5 and 13.8v DC.

4. Disconnect the mains supply and measure the voltage between P1 and P2.

The voltage should now be approximately 12.5v DC from a fully charged battery.

5. Continue with the procedure described in the section on Checking the System.
6. Finally, repeat the checks described above but with a fully working system complete with locks and readers.

Initial Programming

The initialisation of the controller involves clearing its memory and assigning the number of Editor Keys (up to 3) that will be used.

Editor Keys are used to confirm the addition, deletion or change of a user key.

Once you have set the number of Editor Keys, you cannot change the number without clearing the Easikey 250's memory again. However the actual Editor Keys can be removed and added — see the sections on Adding Editor Keys and Deleting Keys. Record the number of Editor Keys on the Programming Worksheet.

Initialising the Easikey 250

1. Power up the Easikey 250 with all three buttons held down:

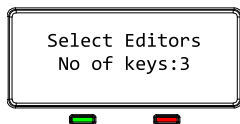

Note: This will clear the memory of the Easikey 250.

2. Change number of Editor Keys?

Press to change
number of Editor Keys

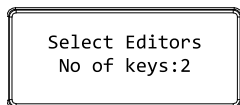
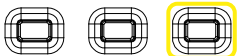

3. Press the Left button to confirm:

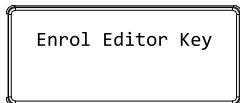
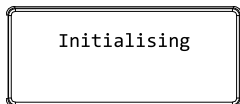
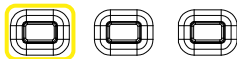

Adding Editor Keys

You must now enrol the first Editor Key, i.e. Editor Key 0. Editor Keys will also act as user keys and allow access through the doors as required.

Like user keys, each Editor Key has an **access level**. The access level specifies whether the key can open Door 1 only, Door 2 only or both. It is not possible to set the access level such that the key cannot open either door.

Editor Key 0 is always set to access both doors — you cannot change this. However, you can set the access level for Editor Keys 1 and 2.

Notes

There is no difference between adding Editor Keys and adding user keys. Depending on the number of Editor Keys that you selected when you initialised the controller, keys number 0 and possibly 1 and 2 will be Editor Keys; all the other keys will be user keys. You can add Editor Keys using any of the methods you use to add user keys. For example, you can add Editor Keys singly or in batch; you can set the access level of Editor Keys; you can start adding an Editor Key and then change its number to be a user key or vice versa.

The instructions below assume that you will add all the Editor Keys in batch when you first initialise the Easikey 250. This is the recommended method. See Adding a Key for other options that are available when adding keys — e.g. if you want to add one Editor Key now and add others later.

Adding Editor Keys

1. Present the first Editor Key:

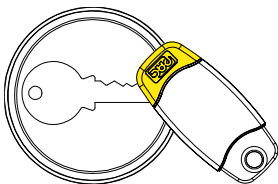

2. Change access level for second Editor Key?

Press to change

Press to change

Door 1 access:

Door 2 access:

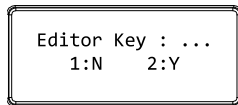

3. Add second Editor Key?

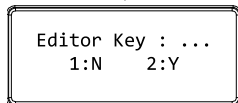
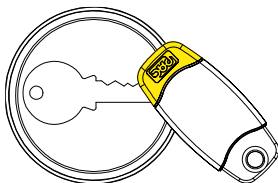

4. Change access level for third Editor Key?

Press to change

Press to change

Door 1 access:

Door 2 access:

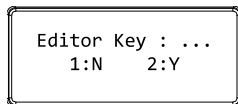

5. Add third Editor Key?

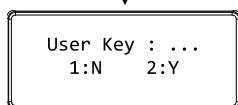
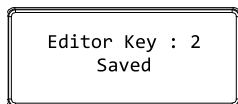
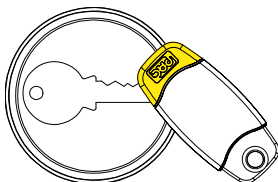

6. Add user keys?

Yes: See the section on Adding a Key.

No: Present an Editor Key, or wait 15 seconds.

Lock Time and Fail-Safe / Fail-Secure Settings

Each of the two lock relays can be set to operate the lock for between 1 and 49 seconds. Each relay may also be set to open or close when operated, allowing the use of Fail-Safe (power to lock) or Fail-Secure (power to release) locks.

Lock 1 may also be set to operate in a Toggle function — see Set-Reset Latch for details.

Adjusting Lock Time and Fail-Safe / Fail-Secure Settings

1. Present an Editor Key:

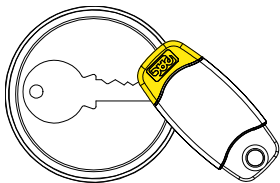

Editor Key : 0
1:Y 2:Y

2. Choose a door:

Press to change
Door 1 settings:



Press to change
Door 2 settings:



Lock1 Time : 3
Fail-Safe

3. Change the lock time?

Press to
change
tens:



Press to
change
units:



Lock1 Time : 10
Fail-Safe

4. Change the Fail-Safe / Fail-Secure Setting?

Press the middle button:



Lock1 Time : 10
Fail-Secure

5. Present the Editor Key again:

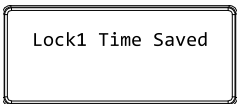
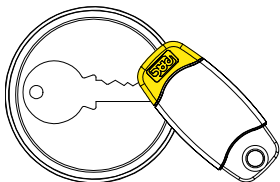

Replacing a Lost Editor Key

All Editor Keys, including Editor Key 0, can be deleted and a new key added in their place using one of the other Editor Keys.

However, if all the Editor Keys are lost, a new Editor Key 0 can be enrolled without having to clear completely all the user key information.

Enrolling a New Editor Key 0

1. Remove power from the Easikey 250.
2. Hold down the Left button and re-apply power:

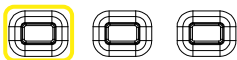

3. Present a new Editor Key 0:

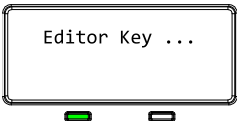
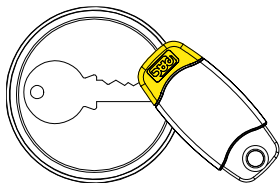

4. Present the same Editor Key again to confirm:

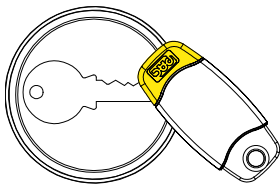

Firmware Version

Displaying the Current Firmware Version Number

1. Remove power from the Easikey 250.
2. Re-apply power:

```
PAC Easikey 250  
V1.00
```

Silent Mode Operation

Configuring the Buzzer on the Controller

1. Present an Editor Key:

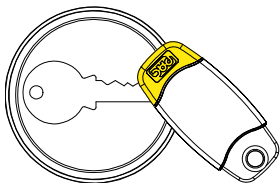

```
Editor Key : 0  
1:Y 2:Y
```

2. Press the Middle button to display the current mode:



```
Controller Only
```

3. Press the Left button to select the required mode:

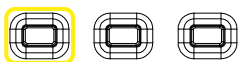

Silent Mode On

4. Present an Editor Key to save:

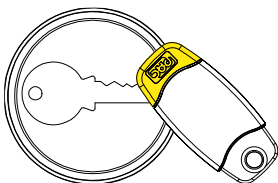

Saved Settings

Notes

The four operating modes are as follows:

- **Controller Only** – Buzzer sounds only when a token is shown to the controller reader.
- **Reader Only** – Buzzer sounds only when access is granted / denied.
- **Silent Mode On** – Buzzer is silent.
- **Silent Mode Off** – Buzzer sounds when access is granted / denied and when a token is shown to the controller reader.

Resetting the controller defaults it to Controller Only mode.

Language Support

Available languages are English, Dutch, German, French, Swedish and Norwegian.

Changing the Language

1. Present an Editor Key:

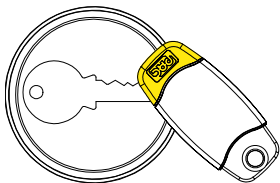

Editor Key : 0
1:Y 2:Y

2. Press and hold the Right button for 2 seconds:

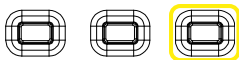

Select Language
English (UK)

3. Press the Left button to select the required language:

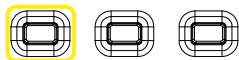

Select Language
English (UK)

4. Present an Editor Key to save:

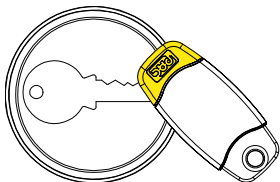

Language Saved

Set-Reset Latch

The **set-reset latch** facility is available on Lock 1 only. It allows the lock relay to be set when a valid key is presented, and reset when a valid key is presented again. This allows the reader to be used like a toggle to operate another system.

Note: When this facility is used, the Request to Exit facility for Door 1 will no longer be available.

Setting Up the Set-Reset Latch Facility

1. Present an Editor Key:

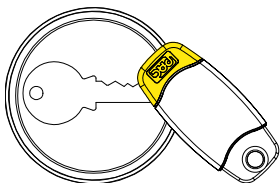

```
Editor Key : 0  
1:Y 2:Y
```

2. Press the Left button:

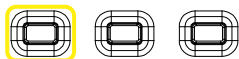

```
Lock1 Time : 3  
Fail-Safe
```

3. Press the Middle button to select Set-Reset Latch:



```
Lock1 Time : --  
Set-Reset Latch
```

4. Present the Editor Key again:

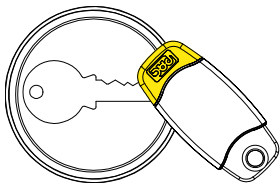

```
Lock1 Time Saved
```

Database Copy

This facility allows the contents of one Easikey 250's memory to be copied to another Easikey 250. The receiving Easikey 250 will have the contents of its memory completely overwritten by the contents of the sending Easikey 250.

Note: You can copy from one Easikey 250 to another Easikey 250, or from an Easikey 99 to an Easikey 250. You cannot copy from an Easikey 250 to an Easikey 99.

Connecting Two Easikey 250 Controllers for Database Copy

1. Remove power from both Easikey 250s.

(Only one Easikey 250 needs to be powered during the copy.)

2. Connect Reader terminal 2 of each Easikey 250 with the following cable:

Sending Controller		Receiving Controller	
-V2	_____	-V2	
S2	_____	A2	
A2	_____	S2	
+V2	_____	+V2	

Use 0.22mm² reader cable for a distance less than 10m.

Copying from One Easikey250 to Another Easikey 250

1. Power up one Easikey 250.
2. On the sending Easikey 250, present an Editor Key:

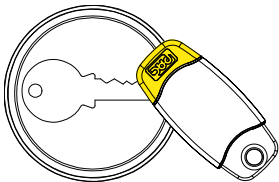

Editor Key : 0
1:Y 2:Y

3. On the sending Easikey 250, press the Middle button for two seconds:

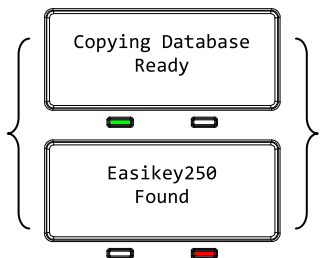

Note: If the cable connection is not correct, only the Copying Database message is displayed.

4. On the sending Easikey 250, press the Left button:

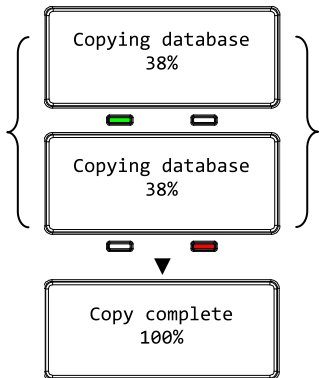
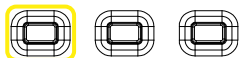

Note: Each packet of data is verified during the transfer process to ensure completeness. The copy will take about 45 seconds to complete. If the process has not started within 15 seconds, a Database Copy Failed message is displayed. You should check the cable wiring.

Copying from an Easikey 99 to an Easikey 250

1. Power up the Easikey 99 or the Easikey 250.
2. On the Easikey 99, present an Editor Key:

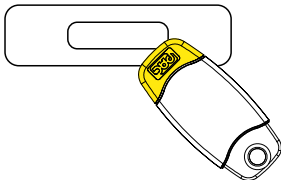

3. On the Easikey 99, press both buttons:



4. On the Easikey 99, press the Blue button:

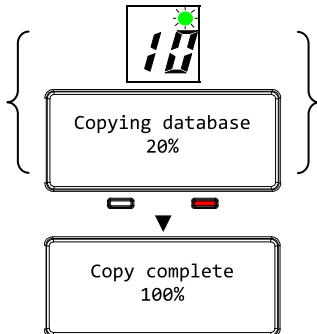

Note: Each packet of data is verified during the transfer process to ensure completeness. The copy will take about 6 minutes to complete.

Dual Controller Option

It is possible to increase the number of keyholders by connecting a reader to the same door channel on two Easikey 250 Controllers. If a key is found in either of the Controllers then the lock relay will operate. The diagrams below show two controllers controlling one Lock 1. To control Lock 2, connect a single reader to channel 2 of both controllers, and the lock through terminals L3 and L4 of each controller. Note that power is supplied to both Easikey 250 controllers.

Note: You can connect two Easikey 250s, or connect an Easikey 250 and an Easikey 99. In the diagrams below, Controller 1 is always an Easikey 250; Controller 2 may be either an Easikey 250 or an Easikey 99. The connections for reader and lock wiring are identical on an Easikey 99 and an Easikey 250.

Reader Wiring

Notice that the reader wiring shown below includes a diode (1N4001, not supplied) at each A1 (or A2) terminal. This is essential to provide correct operation of the reader LED.

The Request to Exit switch can be fitted to either controller.

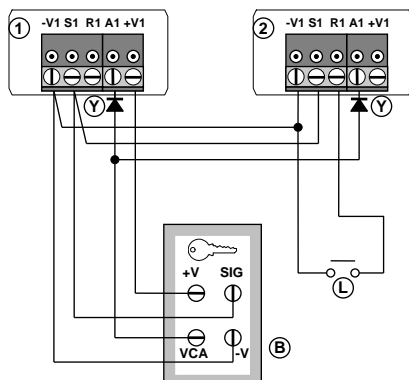

Reader Wiring for Dual Controller Operation

1	Easikey 250 Controller, Door Channel 1	L	Request to Exit
2	Easikey 99 / 250 Controller, Door Channel 1	Y	Diodes, 1N4001
		B	Reader

Lock Wiring

Two different lock wiring configurations are required for Fail-Secure and Fail-Safe locks. Fail-Secure locks are wired so that the relays are in parallel, so that if any relay closes, power will be applied. Fail-Safe locks are wired with the relays in series, so whenever one relay opens, power will be removed.

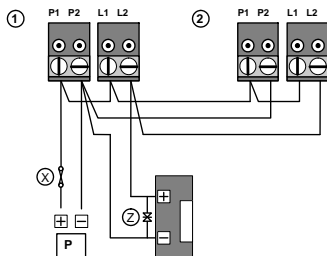

Power and Lock Wiring for Dual Controllers, Fail-Secure

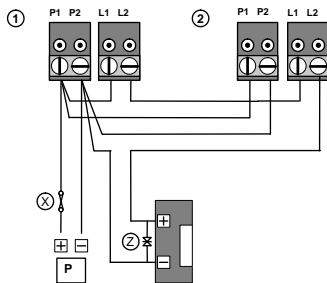

Power and Lock Wiring for Dual Controllers, Fail-Safe

1	Easikey 250 Controller, Lock 1	P	Power Supply
2	Easikey 99 / 250 Controller, Lock 1	X	Fuse
		Z	MOV

Programming

Both Easikey 99 / 250s should be installed and initialised as described in this manual.

However, please note the following:

- You should add the same Editor Keys to each Easikey 99 / 250.
- Ensure that the Lock Release Times for each lock are programmed in exactly the same way on each controller.
- The lock type (Fail-Safe / Fail-Secure) must be the same on both controllers.
- Note to which controller each key is added. If you need to delete a key then you must know to which controller it was added.

Easikey 250 System Troubleshooting

Problem	Possible Cause	Check
Easikey 250 Controller not working.	No Power	Check AC (mains) power supply and fuse. Check voltage at P1, P2 terminals; should be 10-16VDC or 10-12VAC.
	Fuse Blown	Check controller Fuse (1 amp)
Easikey 250 controller OK, but neither reader operates.	No power at readers	Check power at reader, should be 9-16VDC.
	Reader wiring incorrect	Check wiring.
	Key not added	Add key to system.
One reader OK, but other is not.	No power at reader	Check power at reader; should be 9-16VDC.
	Reader wiring incorrect	Check wiring.
	Key does not have access	Check key has access through both doors.
System fails when a lock operates.	Power supply overload	Power supply is not capable of supplying enough power to operate lock.
		Lock is faulty and drawing too much current from power supply.
A key has stopped working.	Faulty reader	If the reader is faulty then other keys will also fail to work – check the reader.
	Faulty key	Other keys will work without problem – replace the key.
	Incorrect programming	Check that the key exists in the controller, and it has been given correct access.

Other Easikey 250 Products

The following items are available for use with the Easikey 250:

Part No.	Description	Notes
20478	OneProx Classic Standard Reader	For internal use.
20068	OneProx Designer Standard Reader	For internal use.
20073	OneProx Classic Mullion Reader	For internal use.
20067	OneProx Designer Mullion Reader	For internal use.
20424 (Black / Yellow) 20483 (Blue / Grey)	OneProx Vandal Resistant Reader	For external use or where resistance to abuse is required. Supplied with 4 Vandal Resistant Screws — requires compatible screwdriver, e.g. 1950 Screwdriver below.
20042 (Black / Yellow) 20049 (Blue / Grey)	OneProx Panel Mount Reader	For fitting in steel panels, e.g. as part of a door entry system.
1950	Screwdriver	For Vandal Resistant Screws used on Vandal Resistant Reader

The following legacy items are also compatible with the Easikey 250:

Part No.	Description	Notes
20377 (Black) 20387 (White)	Easikey Mullion Reader	For internal use.
20378 (Steel) 20388 (Brass)	Easikey Vandal Resistant Reader	For external use or where resistance to abuse is required. Supplied with 4 Vandal Resistant Screws — requires compatible screwdriver, e.g. 1950 Screwdriver above.
20421	Easikey Panel Mount Reader	For fitting in steel panels, e.g. as part of a door entry system.

Standards

The Easikey 250 meets the requirements of the following Council Directives:

- 1999/5/EC R&TTE
- 2006/95/EC Low Voltage
- 2002/95/EC ROHS
- 2002/96/EC WEEE

A Declaration of Conformity is available on request from Stanley Security Products.

The Easikey 250 uses a non-harmonised frequency (10kHz) and has approval from the following members of the European Conference of Postal and Telecommunications

Administrations (CEPT):

- Austria
- Belgium
- Bulgaria
- Cyprus
- Czech Republic
- Denmark
- Estonia
- Finland
- Germany
- Hungary
- Iceland
- Malta
- Netherlands
- Norway
- Poland
- Portugal
- Romania
- Spain
- Sweden
- Switzerland / Liechtenstein
- United Kingdom

Specification

Dimensions

Controller:	198mm W × 90mm H × 28mm D
Readers:	See <i>17991 Oneprox Readers Installation Guide</i> , <i>17063 Easikey Reader Data Sheet</i>

Environment

Temperature:	Controller	0°C to +50°C
	Reader	-15°C to +60°C
Humidity:	Controller	0% to 90% relative humidity, non-condensing
	Reader	Sealed construction

Power Requirements

Input Voltage:	10.5V to 20V DC	
	8V to 14.5V AC 50/60Hz	
Current:	Controller	190mA (Max.)
	Reader	90mA (Max.)

Fuses

A 1A thermally resettable fuse is fitted to protect the power supply.

Cable Requirements

Controller to Reader:	Gauge	0.22mm ² , 4 or 6 core
	Max. Dist.	100m
Controller to Lock:	Gauge	0.5mm ² , 2 core
	Max. Dist.	100m



Security Products

United Kingdom:

PAC – A Stanley Security Products Business

1 Park Gate Close, Bredbury, Stockport, Cheshire, SK6 2SZ

Contact:

Tel: +44 (0) 161 406 3400

Fax: +44 (0) 161 430 8658

E-mail: customerservices@stanleysecurityproducts.com

Web: www.stanleysecurityproducts.co.uk

Technical Support:

Tel: (U.K.) 0845 206 3400 (Int.) +44 (0) 161 430 1340

Fax: +44 (0) 161 406 6749

E-mail: pacsupport@stanleyworks.com

Knowledge Base: www.stanleysecurityproducts.co.uk/support

United States of America:

Stanley Security Products

Contact / Technical Support:

Tel: 800 414-3038

Fax: 800 414-3039

E-mail: support@stanleypac.com

Web: www.stanleysecurityproducts.com

Knowledge Base: www.stanleysecurityproducts.co.uk/support

Stanley is a registered trademark of The Stanley Works, Inc. Unless otherwise indicated, the trademarks and logos displayed are the property of Stanley Security Solutions – Europe Ltd and / or their subsidiary companies.